

Safe Change Filter Housing, Type SCF_{classic}



Aerosol- and Dust Removal Systems

Ventilation systems in areas like laboratories, chemical, pharmaceutical or nuclear industry have to separate toxic particles, radioactive particles and pathogen agents in order to save the environment, the production or the health of the personnel.

Filter systems have to meet high demands regarding the safety and efficiency of particle separation. For these applications Krantz developed the Safe Change Filter Housing, Type SCF_{classic}.

Characteristics

- Compact stainless steel housing
- Clamping of the HEPA filter elements by means of self-adjusting spring system
- Test groove for each filter element
- Special collar for the safe change technology

Various technical high-quality options to equip the system like e.g.

- an automatic disinfection device, to be connected gastightly to the filter housing, utilise a disinfection of the filter housing and filter media
- a gastight shut-off damper, which is integrated in the air inlet- and outlet chamber complete the offer of this product.



Safe Change Filter Housing, Type SCF_{classic} 4 x 1 F6/H13

Clamping device

To guarantee the high efficiency of a HEPA filter element the tightness of the filter seat is very important.

Clamping of the HEPA filter elements by means of self-adjusting spring system, to ensure the tightness requirements for the seat of the filter element according to DIN 25 496, table 3, under conditions of a retreating sealing caused by e.g. aging.

Quick release of the clamping device by means of single acting pneumatic cylinders. For initial filter element fitting and subsequent filter element changes only a (portable) supply of compressed air (6 bar oil free and waterless) is required. This is via a fast acting coupling positioned on front of filter housing.

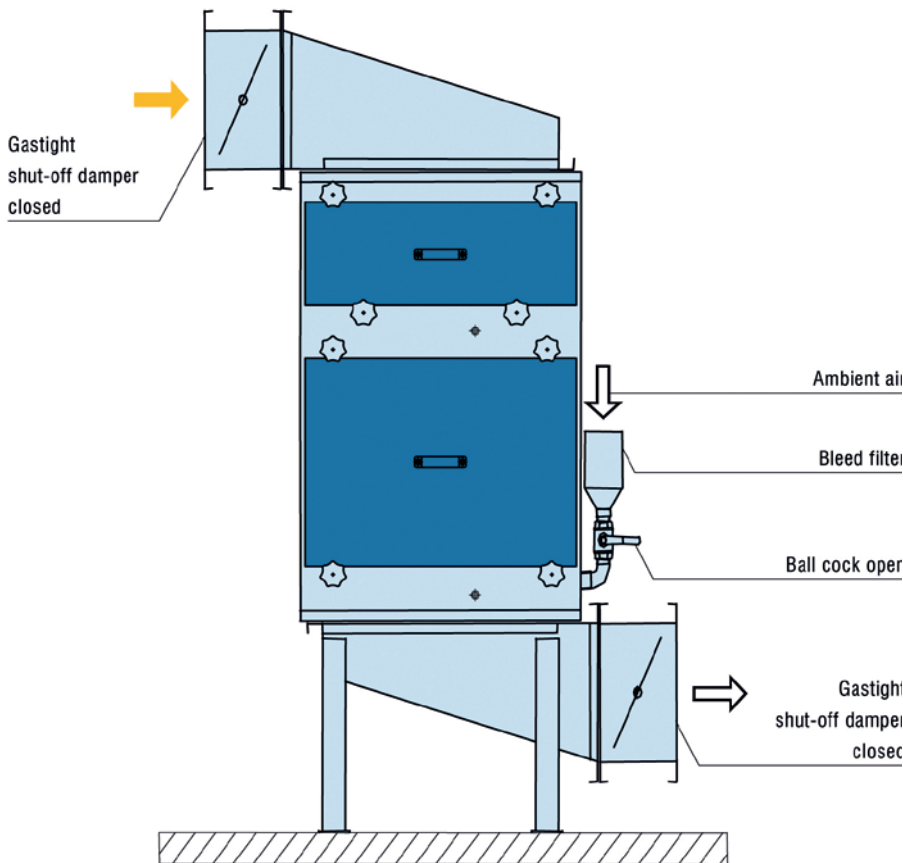
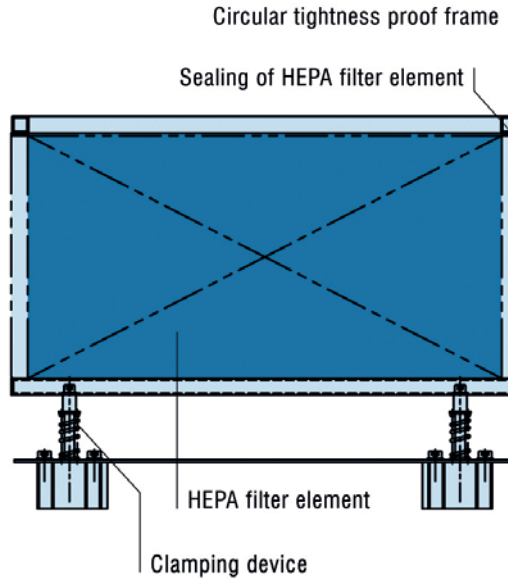

Pressure balancing equipment

In a redundant system the filter housings can be subdivided in such a way, that filter exchange may take place without interruption of operation. The system pressure of the exhaust air installation will exist in the filter housings during operation. After the gastight shut-off dampers have been closed, this pressure remains constant in the housing and will always have to be balanced with the ambient pressure prior to unbolting the housing cover. For this purpose, each of the filter housings can be connected via a bleed filter and a ball cock to the ambient atmosphere.

Dimensions and weights

Filter module SCF_{classic} with HEPA filter stage

$n \times m$ H13, n = numbers of columns,
 m = number of lines

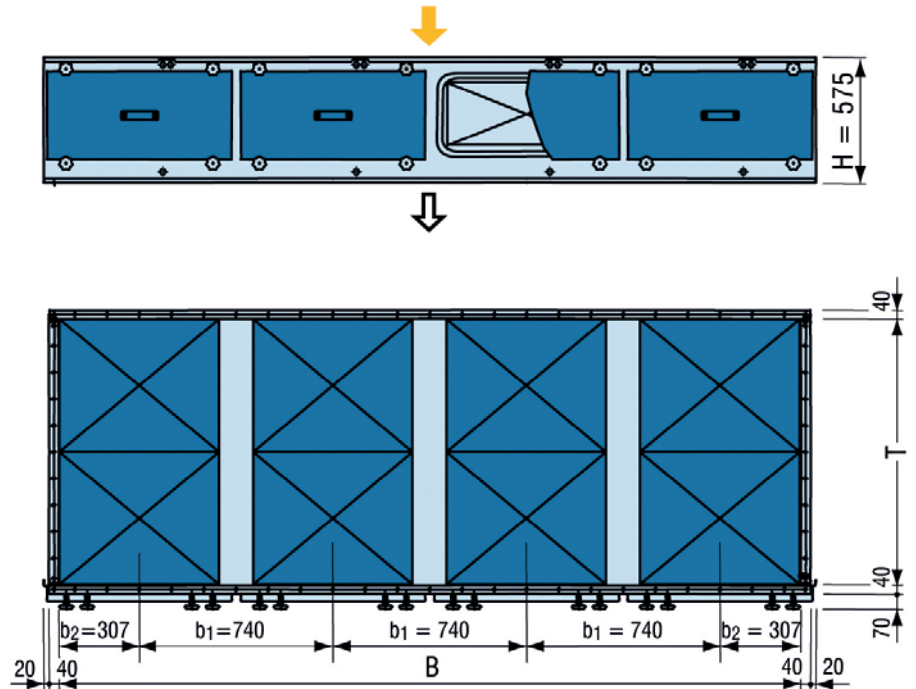

Filtermodul SCF_{classic} with fine dust and HEPA filter stage

$n \times m$ F6/H13, n = number of columns,
 m = number of lines

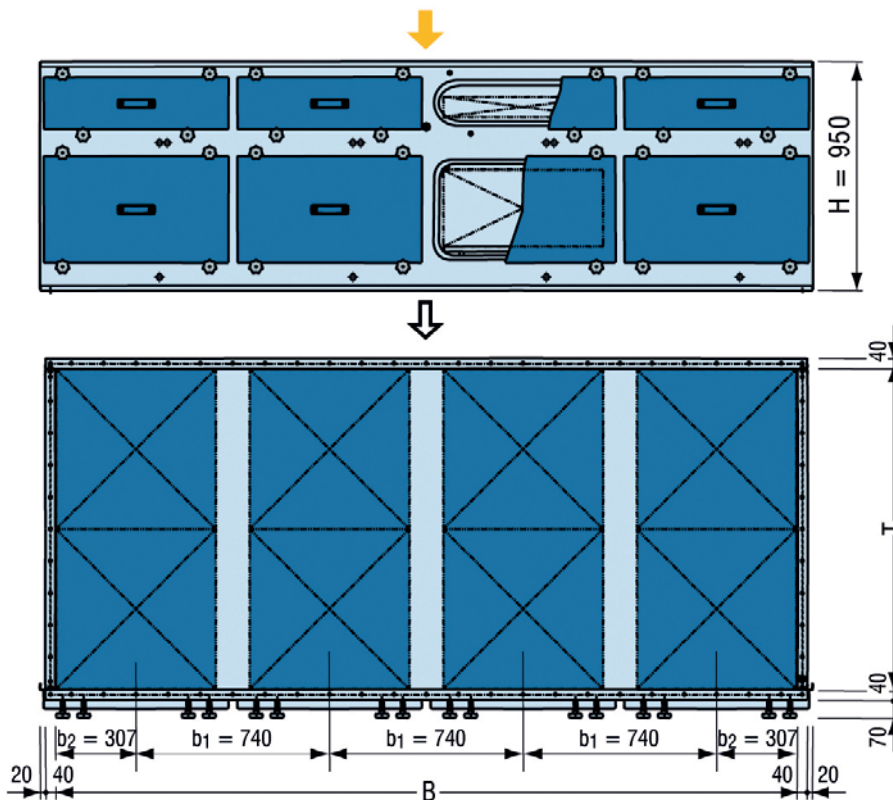

m lines		Filter modul SCF _{classic} with HEPA filter stage		Filter modul SCF _{classic} with fine dust and HEPA filter stage	
		n columns		n columns	
		1	2	1	2
1	\dot{V}_{nom} [m ³ /h]	3 000	6 000	3 000	6 000
	m* [kg]	65	95	95	140
	B [mm]	2 x b ₂ = 614	2 x b ₂ = 614	2 x b ₂ = 614	2 x h ₂ = 614
	T [mm]	614	1 224	614	1 224
2	\dot{V}_{nom} [m ³ /h]	6 000	12 000	6 000	12 000
	m* [kg]	120	175	170	255
	B [mm]	1 x b ₁ + 2 x b ₂ = 1 354	1 x b ₁ + 2 x b ₂ = 1 354	1 x b ₁ + 2 x b ₂ = 1 354	1 x b ₁ + 2 x b ₂ = 1 354
	T [mm]	614	1 224	614	1 224
3	\dot{V}_{nom} [m ³ /h]	9 000	18 000	9 000	18 000
	m* [kg]	170	255	250	365
	B [mm]	2 x b ₁ + 2 x b ₂ = 2 094	2 x b ₁ + 2 x b ₂ = 2 094	2 x b ₁ + 2 x b ₂ = 2 094	2 x b ₁ + 2 x b ₂ = 2 094
	T [mm]	614	1 224	614	1 224
4	\dot{V}_{nom} [m ³ /h]	12 000	24 000	12 000	24 000
	m* [kg]	225	340	325	480
	B [mm]	3 x b ₁ + 2 x b ₂ = 2 834	3 x b ₁ + 2 x b ₂ = 2 834	3 x b ₁ + 2 x b ₂ = 2 834	3 x b ₁ + 2 x b ₂ = 2 834
	T [mm]	614	1 224	614	1 224

* Weights are meant without filter elements

Text for tender

Safe change filter housing, Type SCF_{classic}

For the separation of airborne particles and aerosols, provide for a horizontal arrangement of the following particulate air filter elements:

- Fine dust filter elements;
W/H/D 610/610/150 [mm];
filter class F. acc. to EN 779
- HEPA filter elements;
W/H/D 610/610/292 [mm];
filter class H.. acc. to EN 1822

General

Extreme compact construction, by means of an special arrangement of the filter elements.

All welding are made according to DIN 25 496, item 6.2(4), that means using stabilised steel at austenitic material, e. g. material 1.4541 (AISI/SAE 321 or B.S. 321 S12) and using killed steel at ferretic material. To ensure a good decontamination and disinfection result housing welds are continuous and without gaps.

The clamping devices of the HEPA filter elements are operated from outside and proportioned to ensure the tightness requirements for the seat of the filter element according to DIN 25 496, table 3, under conditions of maximum loading of the filter elements and a retreating sealing.

The filter housing design allows the exchange of the filter elements by means of the safe change technology and without of contamination of operational staff and environment.

Profile sealing made of silicon rubber ensure the tightness of the screwed parts of the filter housing. The sealing system is not sticking, therefore the sealing is easy detachable and also reusable during maintenance work.

Design

- Robust filter housing made of stainless steel, material 1.4301 (AISI/SAE 304) in gastight design according to the tightness requirements of the DIN 25 496, table 3, to insert filter elements.
- Intake device for the positioning of filter elements with a vertical air flow.
- Top and bottom positioned connecting flanges for air inlet- and outlet chamber.
- Insertion ports for filter elements, equipped with a special collar for the safe change technology.
- Special collar, made of aluminium, with two grooves according to DIN 25 466, supplement 1, to take the hollow rubber band for the plastic bag fixation.
- Undercut groove with perfectly matched hollow rubber band to ensure total safety with gastight sealing of safe change plastic bag.
- Maintenance covers made of stainless steel, material 1.4301 (AISI/SAE 304) to ensure a gastight closing of the insertion ports and a protection of the special collar and the rolled plastic bag.
- The covers are fixed to the filter housing, by means of four screwing elements with a star shaped handle. Each cover is equipped with a central positioned transport handle.
- Clamping of the HEPA filter elements by means of self-adjusting spring system, to ensure the tightness requirements for the seat of the filter element according to DIN 25 496, table 3, under conditions of a retreating sealing caused by e. g. aging.
- Quick release of the clamping device by means of single acting pneumatic cylinders. For initial filter element fitting and subsequent filter element changes only a (portable) supply of compressed air (6 bar oil free and waterless) is required. This is via a fast acting coupling positioned on front of filter housing.
- Test groove according to DIN 1946-4 resp. DIN 25 414 for each filter element made of stainless steel. In order to proof the leak free seat of the filter element connect the test groove to the seal test device via fast acting coupling, positioned at the front side on the filter housing.
- Manometer points to connect pressure gauge.

Technical data

Fabricate:	Krantz
Type:	SCF _{classic} n x m F./H..
Nominal air flow per filter element:	3 000 m ³ /h
Admissible design pressure:	± 6 000 Pa
Design temperature:	90 °C
Tightness of filter housing acc. to DIN 25 496:	leakage rate < 3 · 10 ⁻⁵ of nominal air flow at Δp = 2 000 Pa
Tightness of filter seat acc. to DIN 25 496:	leakage rate < 3 · 10 ⁻⁵ of nominal air flow at Δp = 2 000 Pa
Radiation resistance:	≤ 10 ⁵ Gy

Fine dust filter elements

Filter class:	F. acc. to EN 779
Dimensions W × H × D:	610 × 610 × 150 mm
Intake capacity and arrangement:	e.g. 6 pieces (2 columns, 3 lines)

HEPA filter elements

Filter class:	H.. acc. to EN 1822
Dimensions W × H × D:	610 × 610 × 292 mm
Intake capacity and arrangement:	e.g. 6 pieces (2 columns, 3 lines)

Accessories

Air inlet- and air outlet chamber

Standard construction

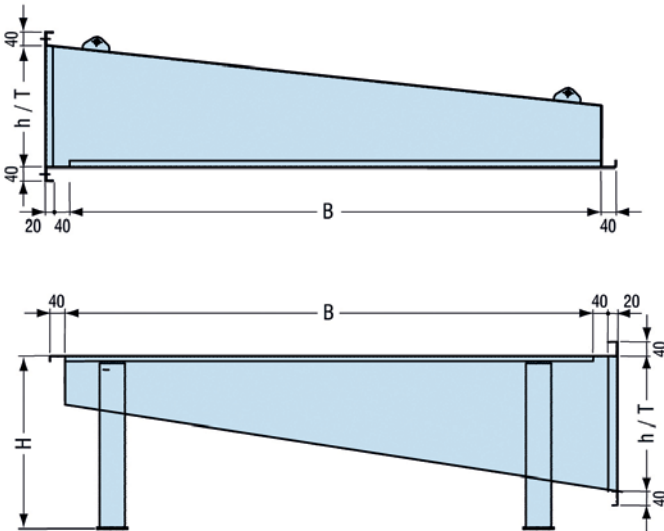

m lines		n columns	
		1	2
1	m _{chamber} [kg]	52	76
	B [mm]	614	614
	H [mm]	342	342
	T [mm]	614	1 224
	h [mm]	200	200
2	m _{chamber} [kg]	85	123
	B [mm]	1 354	1 354
	H [mm]	492	492
	T [mm]	614	1 224
	h [mm]	350	350
3	m _{chamber} [kg]	126	178
	B [mm]	2 094	2 094
	H [mm]	642	642
	T [mm]	614	1 224
	h [mm]	500	500
4	m _{chamber} [kg]	179	245
	B [mm]	2 834	2 834
	H [mm]	842	842
	T [mm]	614	1 224
	h [mm]	700	700

* Weights are meant without filter elements

Options

- Air inlet chamber, made of stainless steel, material 1.4301 (AISI/SAE 304) in gastight design. Chamber with connection flanges to filter housing and raw gas duct including installation for optimal spreading of inlet air (if necessary).
- Air outlet chamber, made of stainless steel, material 1.4301 (AISI/SAE 304) in gastight design. Chamber with connection flanges to filter housing and clean gas duct.
- Pressure gauges for each filter stage for each fine dust and HEPA filter stage, comprising of Magnehelic® differential pressure gauge, instrument holders, connections and connecting lines.
- Aerosol validation points on clean gas side
- Bleed filter system for pressure balancing

Krantz GmbH

Uersfeld 24, 52072 Aachen, Germany

Phone: +49 241 434-1

Fax: +49 241 434-500

info.filter@krantz.de | www.krantz.de

The logo for Krantz GmbH, featuring the word "Krantz" in a stylized, blue, cursive script font.